

GLOSSARY OF TERRAIN-VEHICLE TERMS

INTRODUCTION

THE STANDARDIZATION Committee of the International Society for Terrain-Vehicle Systems (ISTVS) has been working on a set of standard terms to be used by investigators in the field of off-road operations, so that better communication might result. Standards in the following categories are being developed:

- I. Terrain characteristics
 - A. Soils
 1. Types
 2. Strength characteristics
 - B. Geometry
- II. Vehicle physical characteristics
- III. Vehicle performance characteristics
 - A. Directly measurable quantities
 - B. Derived quantities
 - C. Qualitative terms
- IV. Test apparatus
 - A. Terrain measuring instruments
 - B. Vehicle measuring instruments
 - C. Laboratory equipment.

The Committee has completed two of these categories, Terrain geometry characteristics and Vehicle physical characteristics. These are presented here for the comments of members of the Society. It is anticipated that all appropriate comments received by members of the Committee will be incorporated into these standards, and the final version will be submitted to the International Conference in 1969. The Committee, members of which are listed below, therefore welcomes all suggestions, corrections, or additions.

I. ROBERT EHRlich, Chairman
Davidson Laboratory
Stevens Institute of Technology
Castle Point Station
Hoboken, New Jersey 07030

MARVIN P. MEYER
Chief, Classification and Prediction Section
U.S. Army Engineer Waterways Experiment Station
P.O. Box 631
Vicksburg, Mississippi 39180

DAVID SLOSS
University of Detroit
Department of Civil Engineering
4001 W. McNichols Road
Detroit, Michigan 48221

ZOLTAN JANOSI

Land Locomotion Division

U.S. Army Tank-Automotive Command

Warren, Michigan 48090

ANDREW J. GREEN

Chief, Vehicle Dynamics Section

U.S. Army Engineer Waterways Experiment Station

P.O. Box 631

Vicksburg, Mississippi 39180

TERRAIN GEOMETRY CHARACTERISTICS

1. *Cross-country terrain*. Terrain not specifically improved for vehicular traffic. (ISTVS)*
2. *Environment*. The total of those natural or man-induced phenomena that influence the performance of vehicles. (ISTVS)
3. *Environmental effect*. A measurable or otherwise definable effect imposed by a specific environmental factor, or by a combination of such factors. (ISTVS)
4. *Environmental factor*. A specific attribute of the environment that can be described adequately in quantitative terms, e.g. temperature. (ISTVS)
5. *Environmental factor class*. A specific range of values for an environmental factor. (ISTVS)
6. *Hydrologic geometry feature*. A channel, stream, pond, lake, or other depression that contains water. When dry, the configuration is not considered a hydrologic geometry feature (see Lake, River, Stream). (ISTVS)
7. *Lake*. A hydrologic geometry feature that confines water. (ISTVS)
8. *Landscape type*. A region throughout which a specific assemblage of environmental factor classes occurs, and throughout which those factor classes are related to each other in a similar way. (ISTVS)
9. *Obstacle*. A definable environmental feature that inhibits the movement of a vehicle. (ISTVS)
10. *Obstacle, lateral*. An unsurmountable terrain feature or a combination of such features that forces a vehicle to deviate laterally from a desired path. (ISTVS)
11. *Obstacle, longitudinal*. A surmountable terrain feature that inhibits the movement of a surface vehicle by forcing it to slow down as the feature is negotiated. (ISTVS)
12. *Obstacle, vertical*. A longitudinal obstacle that forces a vehicle to move in the vertical plane while surmounting it. (ISTVS)
13. *Off-road*. Away from terrain specifically improved for vehicle use. (ISTVS)
14. *Profile*. A geometric representation of a terrain surface as an elevation-distance curve. (ISTVS)
15. *River*. A hydrologic geometry feature that channelizes water flow. To provide guidance for uniform usage, the following tentative minimum dimensions must be satisfied for the feature to be considered a river at the cross section under consideration:

*(ISTVS) following a definition indicates that the definition was composed by the ISTVS Standardization Committee.

Width of water surface: 20 ft (610 cm)

Depth: 6 in. (15 cm) (ISTVS)

16. *Slope*. The angle that a surface makes with the horizontal [1].
17. *Slope facet*. A surface that is at essentially the same angle with the horizontal for a determinable area [1].
18. *Slope length*. The linear distance from one change of slope to another. (ISTVS)
19. *Step height*. The perpendicular height of a step on a slope facet (see Fig. 1). (ISTVS)

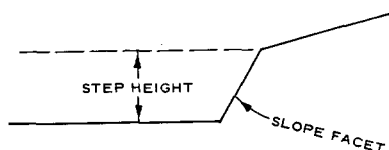

FIG. 1.

20. *Stream*. A hydrologic geometry feature that channelizes water flow, but does not meet the minimum requirements to be considered a river. (ISTVS)
21. *Surface geometry*. The three-dimensional configuration of the terrain surface. (ISTVS)
22. *Terrain*. The total of all man-induced or natural non-meteorological phenomena that influences the performance of vehicles. (ISTVS)
23. *Terrain break angle*. The angle between two adjacent slope facets. (ISTVS)
24. *Terrain factor (feature)*. A specific attribute of the terrain that can be described in quantitative terms. (ISTVS)
25. *Terrain trafficability*. The ability of terrain to support the passage of vehicles [2].
26. *Terrain type*. A region throughout which a specific assemblage of factors occurs. (ISTVS)
27. *Vehicle environment*. All environmental factors that affect the operation of a vehicle [2].

VEHICLE PHYSICAL CHARACTERISTICS

The physical characteristics of a vehicle are those factors that are necessary to describe its shape, weight, type, and operational capabilities in all environments. In this portion of the proposed terminology, vehicles have been typed generally according to their running gear, as follows:

Type I: Wheeled vehicles

Type II: Tracked vehicles

Type III: All others (pneumatic track, bouyant screw, half-track, ground effect machines, walking machines)

The terms needed to describe the vehicle and its components have been divided into two major groups: (a) general vehicle terms, and (b) traction and transport element terms. The latter has been subdivided further to deal with the three types of vehicles listed above. Since vehicles that would classify as Type III are being proposed or developed in increasing numbers, and vehicles of this type are changing constantly, no terms are listed for them at this time.

The terms defined below are listed, together with the appropriate fundamental units or dimensionless units of measure, in Table 1.

Vehicle terms

28*. *Angle of approach, vehicle.* The maximum angle, equal to or less than 90° , that can be formed by the intersection of the vehicle contact plane and a plane tangent to the forward part of the foremost traction or transport elements and touching the foremost part of the vehicle body (see Fig. 2). (ISTVS)

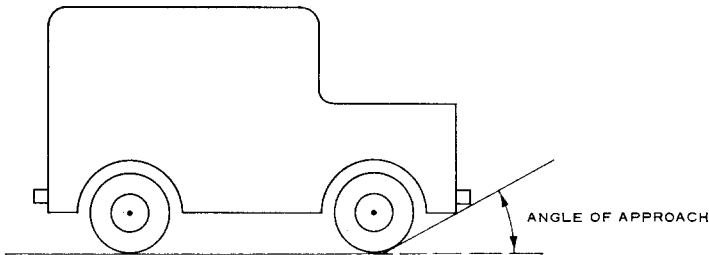

FIG. 2.

29. *Angle of break, vehicle.* The maximum angle that can be formed beneath a wheeled vehicle by the intersection of two planes touching to any two adjacent traction elements with the apex touching the vehicle (see Fig. 3). (ISTVS)

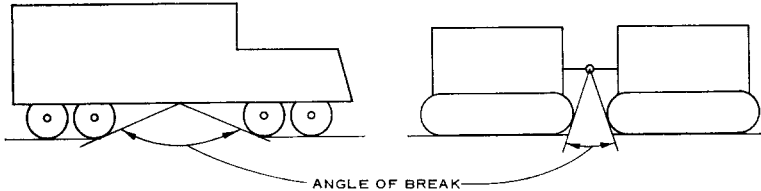

FIG. 3.

30. *Angle of departure, vehicle.* The maximum angle, equal to or less than 90° , that can be formed by the intersection of the vehicle contact plane and a plane tangent to the rearward part of the rearmost traction or transport elements and touching the rearmost part of the vehicle body (see Fig. 4). (ISTVS)

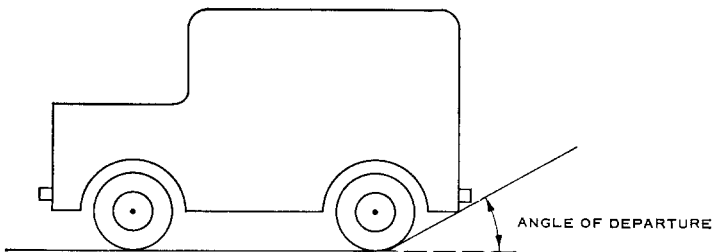

FIG. 4.

31. *Angle of pitch.* This angle pertains to the $X-Z$ plane (see Fig. 5). For multi-unit vehicles, this is the angle between the X -axes of adjacent units (see Fig. 6) [3].

*Numbering continued in sequence for ready reference purposes.

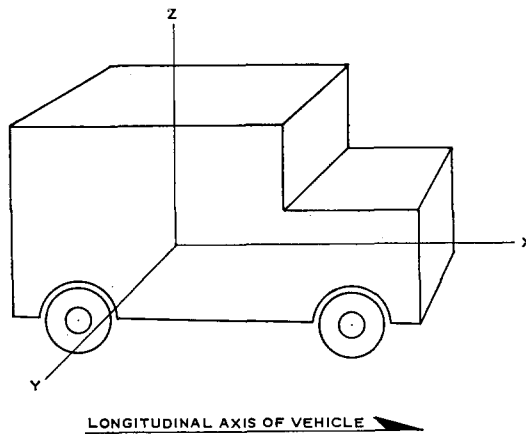

FIG. 5.

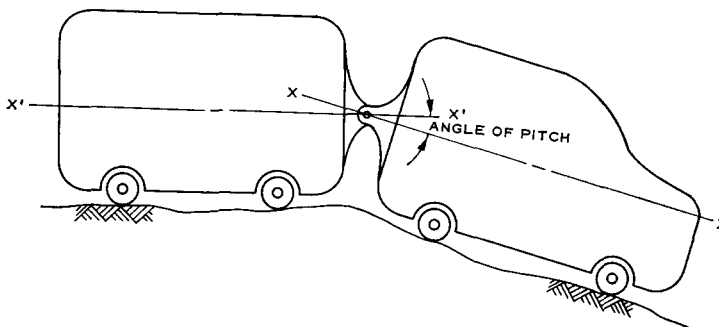

FIG. 6.

32. *Angle of roll.* This angle pertains to relative movements in the $Y-Z$ plane (see Fig. 5). For multi-unit vehicles, this is the angle between the Z -axes of adjacent units (see Fig. 7) [3].

33. *Angle of yaw.* This angle pertains to relative movements in the $X-Y$ plane (see Fig. 5). For multi-unit vehicles, this is the angle between the Y -axes of adjacent units (see Fig. 8) [3].

34. *Cruising range.* The total mileage a vehicle can operate on the usable fuel in its tanks [4]. Note: This is a function of surface condition, mission, payload, and other factors.

35. *Damping rate.* The rate at which the vehicle suspension system element dissipates energy. (ISTVS)

36. *Fordability.* The depth of water that a vehicle can negotiate under its own power (Fordability is unlimited for vehicles that can swim.) [4].

37. *Freeboard.* The distance from the waterline to the lowest point on the rim of a static floating vehicle in still water (see Fig. 9). (ISTVS)

38. *Gradeability.* The maximum grade (expressed in per cent or degrees) that a fully loaded and equipped vehicle can climb at a constant speed on a smooth concrete course when operating in a specified gear [4].

39. *Ground clearance.* The vertical distance from the contact plane of a vehicle to the lowest point on the vehicle's undercarriage or hull. (ISTVS)

GLOSSARY OF TERRAIN-VEHICLE TERMS

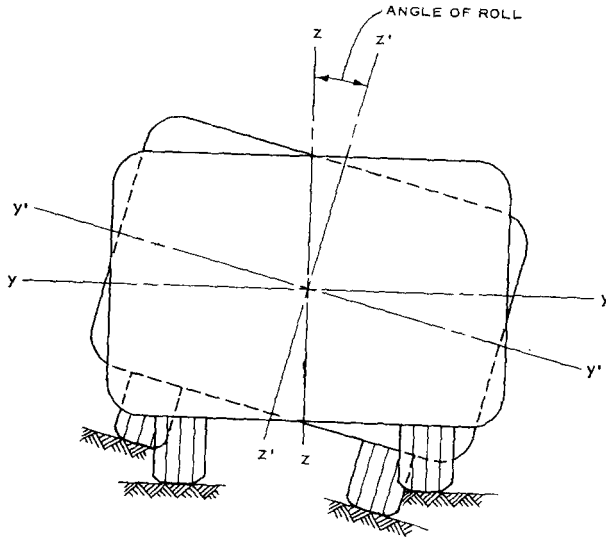

FIG. 7.

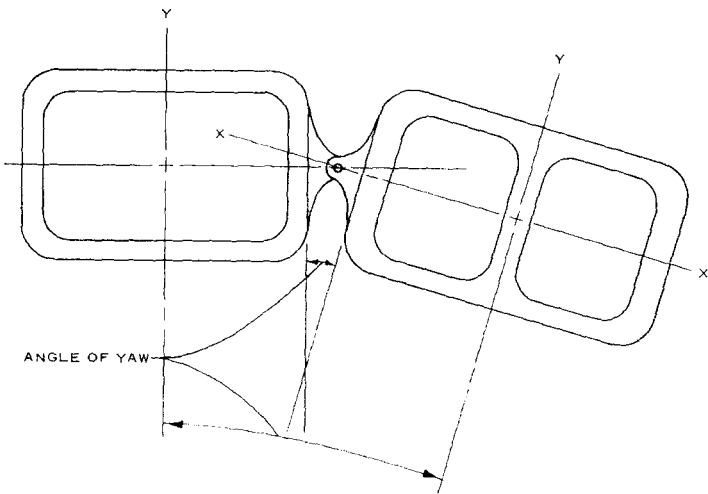

FIG. 8.

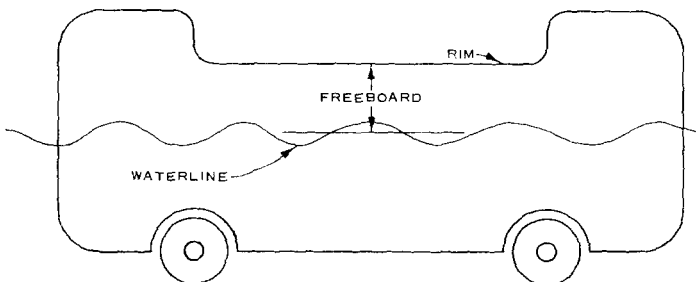

FIG. 9.

40. *Height, overall.* The distance from the contact plane to the uppermost point on the vehicle, including any protruding extremities [3].

41. *Height, reducible.* The minimum height that can be achieved without major disassembly. (ISTVS)

42. *Length, overall.* The maximum distance from the front to rear of a vehicle, including any protruding extremities [3].

43. *Length, reducible.* The minimum length that can be achieved without major disassembly. (ISTVS)

44. *Slope (lateral) stability.* The steepest slope that the fully loaded vehicle can traverse slowly on a course perpendicular to the direction of the slope without over-turning, measured in percent or degrees [4].

45. *Spring rate.* The force-displacement relation for the vehicle component(s) under consideration. (ISTVS)

46. *Steering types*

(a) *Articulated.* A system whereby the steering forces are generated by yaw interaction between two or more units of the vehicle. (ISTVS)

(b) *Conventional (Ackerman).* A system whereby the steering of wheeled vehicle is such that, as far as possible, the axes of all axles meet at a common point [2].

(c) *Skid.* A system whereby tracked and wheeled vehicles are steered when the tracks or wheels have no angular freedom in relation to the vehicle hull, steering being effected by changing the relative speeds of the running gear on each side of the vehicle. (ISTVS) Skid steering is further defined by the types of turns.

(1) *Free.* The turn obtained when the drive to one side is disengaged, but the other side is not braked [2].

(2) *Neutral.* A turn obtainable in some steering systems with the gear-box in neutral [2].

(3) *Pivot.* A turn about a vertical axis through the center of the vehicle when the speed of the drive on each side of the vehicle is equal in magnitude but opposite in sense [2].

(4) *Power.* A turn in which both sides are positively driven at different speeds [2].

(5) *Slide.* The turn obtained when the movement of the running gear of one side of the vehicle is stopped [2].

(d) *Regenerative skid.* A system whereby the wheels and tracks on each side of the vehicle are connected together mechanically, hydraulically, or electrically, such that a turning moment can be applied to the vehicle by differential application of torque. (ISTVS)

(e) *Wagon.* A system whereby the entire steering axle rotates relative to the body. (ISTVS)

47. *Sweep or swept area.* The total projected area covered by a vehicle negotiating a turning maneuver. (ISTVS)

48. *Swimability.* The ability of a vehicle with an inherent floating capability to steer and propel itself while floating across a water obstacle. (ISTVS)

49. *Traction or transport elements.* Any element of a vehicle that is designed to provide support and/or traction for a vehicle travelling on a surface (e.g. tires, tracks, feet, screws, etc.). (ISTVS)

50. *Turning radius.* The radius of the arc described by the center of the path made by the outside front wheel (or outside track) of a vehicle when making its shortest complete turn [4].

51. *Vehicle.* Any device used to transport a payload. (ISTVS)

52. *Vehicle, other.* A vehicle not making exclusive use of tracks or wheels as traction and transport elements. (ISTVS)

53. *Vehicle, tracked.* A vehicle utilizing track or track-like traction and/or transport elements exclusively. (ISTVS)

54. *Vehicle, wheeled.* A vehicle utilizing wheel or wheel-like traction and/or transport elements exclusively. (ISTVS)

55. *Weight, curb, or static.* The weight of a fully equipped vehicle in operating condition with full fuel load, lubricants, and water (when required), but without crew or payload unless otherwise specified [4].

56. *Weight, gross.* The total weight of a vehicle, including payload. (ISTVS)

57. *Weight, payload.* The weight of cargo and/or passengers, including crew, imposed on vehicle. (ISTVS)

58. *Weight-payload ratio.* The curb weight of a vehicle divided by its payload. (ISTVS)

59. *Weight, sprung.* The weight of the vehicle that is supported by the springs [5].

60. *Weight transfer.* The change in load on the traction and transport elements of a vehicle under specified operating conditions when compared to the static vehicle on level ground. (ISTVS)

61. *Weight, unsprung.* The weight of the vehicle that is not carried by the springs. (ISTVS)

Tire terms

62. *Lug (see also Tread).* Any elements of the tire tread intended to improve traction or propulsion. (ISTVS)

63. *Lug angle.* The acute angle between the center line of the lug and the plane of rotation of the tire (see Fig. 10). (ISTVS)

64. *Lug base.* The projected thickness or width of the lug at the points where the projected planes of the leading and trailing sides meet the tread face (see Fig. 11) [6].

65. *Lug face.* The outermost surface of the lug (see Fig. 11) [6].

66. *Lug fillet.* The curved section used to blend the sides of the lug into the tread face (see Fig. 11) [6].

67. *Lug height.* The distance measured from the tread face to the lug face, measured at the tire center line unless otherwise specified (see Fig. 11). (ISTVS)

68. *Lug length.* The curvilinear distance measured from end to end along the center line of the face of the lug (see Fig. 10). (ISTVS)

69. *Lug pitch.* The distance between the leading sides of adjacent lugs on the same side of a tire measured at the center line (see Fig. 10). (ISTVS)

70. *Lug sides.* The surface of the lug between the undertread face and the lug face (see Fig. 11) [6].

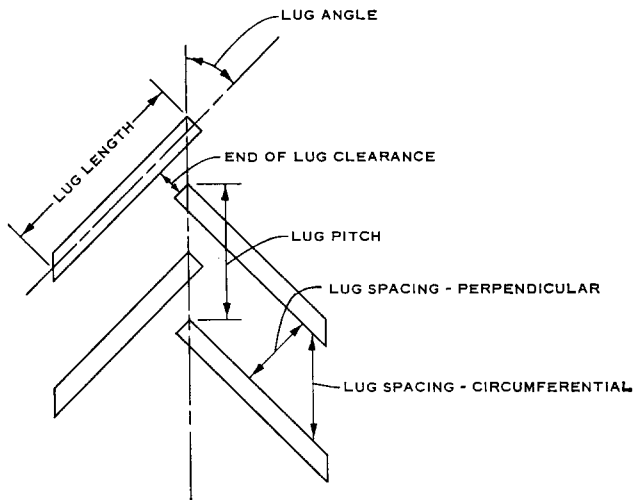

FIG. 10.

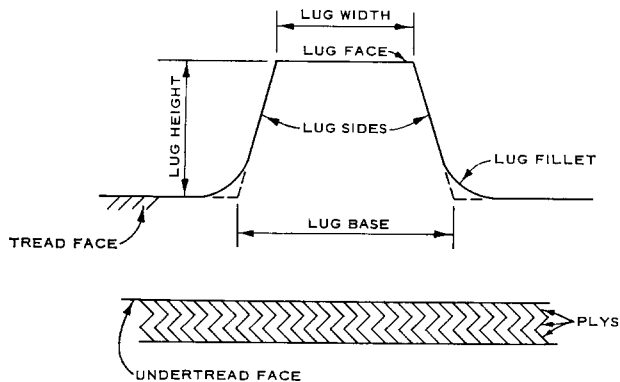

FIG. 11.

71. *Lug space, circumferential.* The distance from the leading side of a lug to the trailing side of the lug ahead, measured parallel to the center line of the tire (see Fig. 10) [6].

72. *Lug space, perpendicular.* The distance measured perpendicularly from the leading side of a lug to the trailing side of the lug ahead of it (see Fig. 10) [6].

73. *Lug width.* The width of the face of the lug measured at right angles to the center line of the face of the lug (see Fig. 11) [6].

74. *Ply, belt (or cinch band).* The plies of a tire having the cords, which are intended to furnish circumferential strength, nearly parallel to the plane of tire rotation. (ISTVS)

75. *Ply, breaker.* The plies whose cords run approximately parallel to the plane of the tire's cross section. (ISTVS)

76. *Ply, diagonal.* The plies whose cords run diagonally from bead to bead (see Fig. 12). (ISTVS)

77. *Ply rating.* An index of strength that does not necessarily represent the

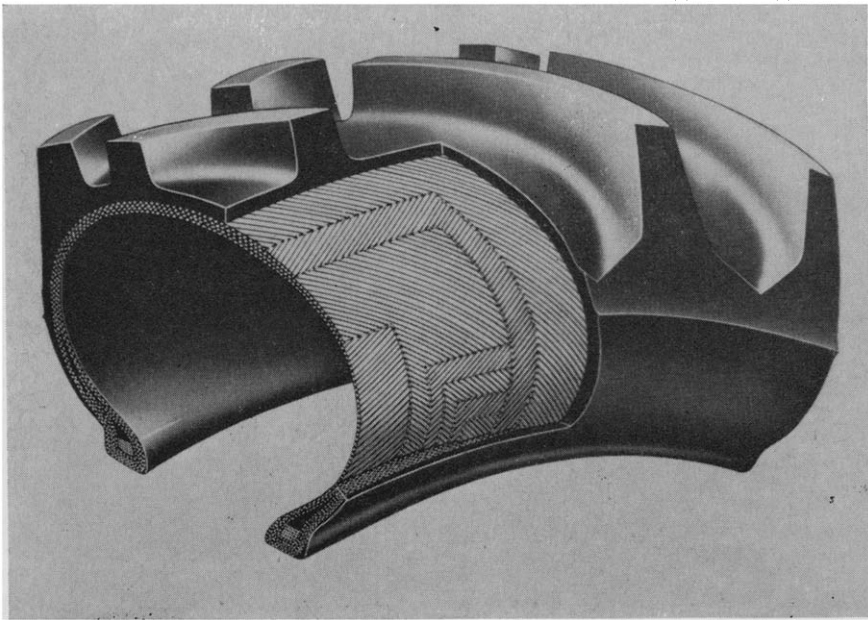

FIG. 12.

number of cord plies in the tire. It identifies a given tire with its maximum recommended load when used in a specific type of service [6].

78. *Rim diameter.* The diameter at the lip of the rim flange (see Fig. 13) [7]

79. *Rim diameter, nominal.* The diameter at the shoulder of the rim. It is the rim diameter that appears in the designation of the tire size (e.g. the "16" in the "6.00-16") (see Fig. 13) [7].

80. *Tire carcass diameter.* The outside diameter, exclusive of tread, of the inflated, but unloaded tire. Equals the rim diameter plus twice the carcass section height (see Fig. 13) [7].

81. *Tire carcass section height, loaded.* The minimum distance from the lowest point on the lip of the rim flange to the unyielding plane surface in which the loaded tire is resting, exclusive of tread height (see Fig. 13) [7].

82. *Tire carcass section height, unloaded.* The distance from the lip of the rim flange to the periphery of the tire, exclusive of tread, measured along the vertical center line of the cross section of the inflated but unloaded tire (see Fig. 13) [7].

83. *Tire contact area.* The portion of the tire in contact with the supporting surface. Interruptions of the contact area due to tread patterns are considered part of the contact area [7].

84. *Tire contact pressure.* The load on the tire divided by the tire contact area [7].

85. *Tire contact length.* The maximum length of the tire contact area, measured parallel to the plane of rotation of the tire [7].

86. *Tire contact width.* The maximum width of the tire contact area, measured perpendicular to the plane of rotation of the tire [7].

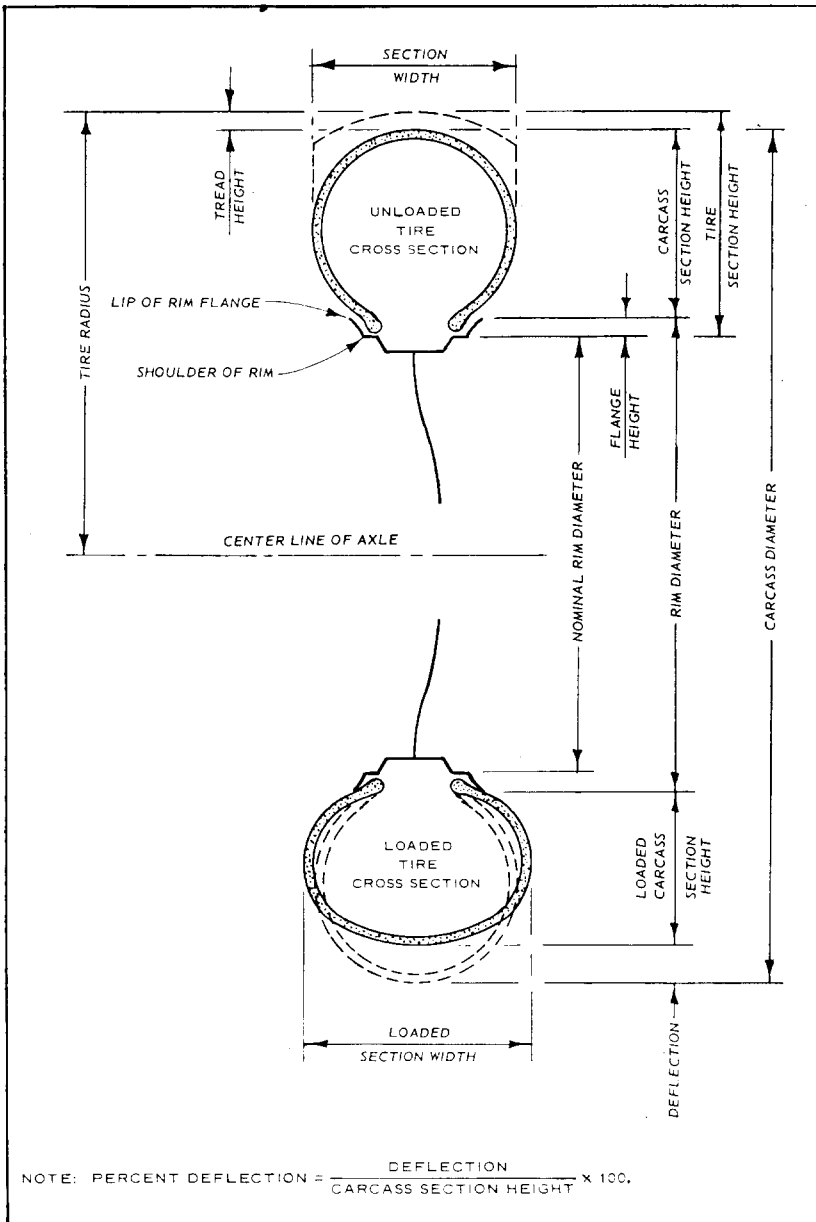

FIG. 13.

87. *Tire deflection.* Any inward radial displacement of a point on the tire surface from its position on the inflated but unloaded tire, unless otherwise specified (see Fig. 13). (ISTVS)

88. *Tire deflection, maximum hard surface.* The difference between carcass section height and the loaded carcass section height [7].

89. *Tire deflection, maximum in-soil deflection.* The maximum deflection measured on the center line of the cross section of the tire as it moves in the soil [7].

90. *Tire, diagonal ply (conventional)*. Tire construction in which the cords of the body plies run diagonally from bead to bead (see Fig. 12). (ISTVS)

91. *Tire diameter*. The outside diameter, including tread, of the inflated but unloaded tire. Equals the carcass diameter plus twice the tread height at the center line of the cross section. In Fig. 13, one half of the tire diameter, i.e. the tire radius, is shown [7].

92. *Tire inflation pressure*. For air-filled tires, it is the gage pressure measured with the valve in any position. For tires containing liquid, it is the gage pressure measured with an "air water" gage while the valve is in the bottom position [6].

93. *Tire, radial ply*. A tire whose cords in general run in either a radial or circumferential direction (Fig. 14). (ISTVS)

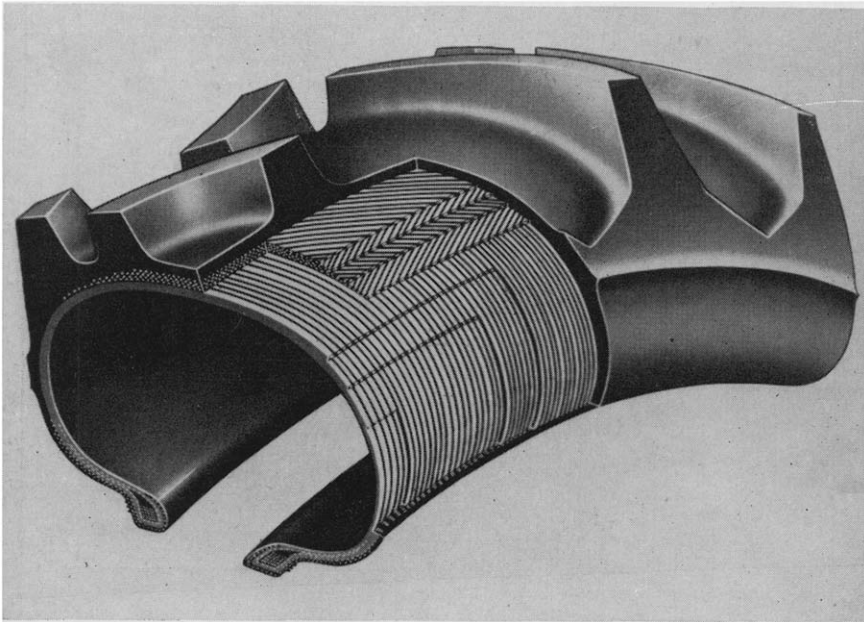

FIG. 14.

94. *Tire rolling circumference*. The forward advance per revolution of the loaded tire when towed on a flat, level, unyielding surface [7].

95. *Tire rolling radius*. The measured rolling circumference divided by 2π . (ISTVS)

96. *Tire section height (see also Tire carcass section height)*. The distance from the shoulder of the rim to the periphery of the tire, including tread, measured along the vertical center line of the cross section of the inflated but unloaded tire (see Fig. 13) [7].

97. *Tire section width, loaded*. The maximum outside width of the cross section of the loaded tire when the tire is resting on an unyielding, horizontal plane surface (see Fig. 13) [7].

98. *Tire section width unloaded*. The maximum outside width of the cross section of the inflated but unloaded tire (see Fig. 13) [7].

99. *Tire tread*. Anything applied to the carcass surface (on the outer surface) intended to serve as a wearing surface and increase the traction or propulsion capacity of a vehicle. (ISTVS)

100. *Tire tread height*. The perpendicular distance from the undertread face to the tread face, measured at the center line unless otherwise specified. (ISTVS)

101. *Tire radius*. The radius of curvature of the face of the lugs or tread measured at right angles to the plane of rotation of the tire with the tire mounted on its recommended rim and inflated to recommended pressure [6].

102. *Tread width*. Synonymous with Tire contact width [7].

103. *Undertread face*. The outermost surface of the rubber on the carcass where no tread is located [6].

Track terms

104. *Grouser*. A projection on a traction element intended to improve propulsion (see Fig. 15). (ISTVS)



FIG. 15.

105. *Grouser face*. The outermost surface of the grouser. (ISTVS)

106. *Track cleat*. Synonymous with Grouser. (ISTVS)

107. *Track ground contact area*. The sum of the areas of the elements in contact with the surface. Includes interruptions due to openings within or between grousers [7].

108. *Track ground contact area, nominal*. The product of the nominal track ground contact length and the track ground contact width. (ISTVS)

109. *Track ground contact length*. The length of that portion of the tracks in contact with the surface (see Fig. 16). (ISTVS)

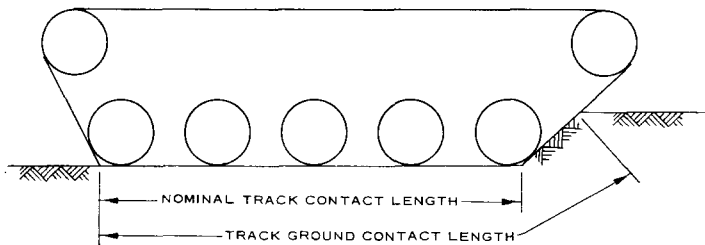

FIG. 16.

110. *Track ground contact length, nominal*. The length of track in contact with a flat, unyielding surface. (ISTVS)

111. *Track ground contact pressure*. The weight of the vehicle divided by the ground contact area [7].

112. *Track ground contact pressure, nominal.* The quotient obtained when the vehicle gross weight is divided by the sum of the nominal ground contact areas of all tracks. (ISTVS)

113. *Track ground contact width.* The maximum width of the contact elements

114. *Track grouser height.* The distance measured from the track shoe face to including connecting links. (ISTVS)
the grouser face (see Fig. 15) [6].

115. *Track grouser spacing or pitch.* The distance between corresponding points on adjacent grousers. (ISTVS)

116. *Track grouser width.* The overall width of a grouser (see Fig. 15) [6].

117. *Track link pitch.* The distance between center lines of adjacent track coupling elements. (ISTVS)

118. *Track pad or plate.* A replaceable traction surface element of a track shoe. (ISTVS)

119. *Track pitch.* The distance between adjacent drive sprocket contact points. (ISTVS)

120. *Track shoe.* The rigid track element that is connected by means of hinged or flexible devices to form the track. (ISTVS)

121. *Track shoe face.* The outermost surface of the track shoe, exclusive of grouser. (ISTVS)

122. *Track types*

(a) *Band track.* A track consisting of one or more bands either continuous or made up of shorter lengths joined together and having a larger number of points of flexure than is required by the normal pitch of the sprocket [2].

(b) *Girderized track.* A track with links restrained from bowing due to the vertical soil reaction [2].

(c) *Live track.* A track consisting of a connected series of links with an elastic medium in the joints so joined that some of the energy put into the joints during flexure is regained. (ISTVS)

(d) *Spaced-link track.* A track consisting of elements so designed that the grouser height to spacing ratio is intended to achieve general soil failure between the grousers. (ISTVS)

TABLE 1. SUMMARY OF TERMS.

Terms	Units*
<i>General vehicle terms</i>	
Angle of approach, vehicle	Degrees
Angle of break, vehicle	Degrees
Angle of departure, vehicle	Degrees
Angle of pitch	Degrees
Angle of roll	Degrees
Angle of yaw	Degrees

*Degrees=angular measurement
L=length
F=force

T=time
N/A=units not applicable
D=dimensionless

Cruising range	<i>L</i>
Damping rate	<i>FTL</i> ⁻¹
Fordability	<i>L</i>
Freeboard	<i>L</i>
Gradeability	Degrees (or per cent)
Ground clearance	<i>L</i>
Height, overall	<i>L</i>
Height, reducible	<i>L</i>
Length, overall	<i>L</i>
Length, reducible	<i>L</i>
Slope (lateral) stability	Degrees (or per cent)
Spring rate	<i>FL</i> ⁻¹
Steering	<i>N/A</i>
Sweep or swept area	<i>L</i> ²
Swimability	<i>N/A</i>
Traction or transport elements	<i>N/A</i>
Turning radius	<i>L</i>
Vehicle	<i>N/A</i>
Vehicle, other	<i>N/A</i>
Vehicle, tracked	<i>N/A</i>
Vehicle, wheeled	<i>N/A</i>
Weight, curb or static	<i>F</i>
Weight, gross	<i>F</i>
Weight, payload	<i>F</i>
Weight-payload ratio	<i>D</i>
Weight, sprung	<i>F</i>
Weight, transfer	<i>F</i>
Weight, unsprung	<i>F</i>

Traction and transport element terms

Tire terms

Lug	<i>N/A</i>
Lug angle	Degrees
Lug base	<i>L</i>
Lug face	<i>L</i> ²
Lug fillet	<i>N/A</i>
Lug height	<i>L</i>
Lug length	<i>L</i>
Lug pitch	<i>L</i>
Lug sides	<i>L</i> ²
Lug space, circumferential	<i>L</i>
Lug space, perpendicular	<i>L</i>
Lug width	<i>L</i>
Ply, belt (or Cinch belt)	<i>N/A</i>
Ply, breaker	<i>N/A</i>
Ply, diagonal	<i>N/A</i>

Ply rating	<i>N/A</i>
Rim diameter	<i>L</i>
Rim diameter, nominal	<i>L</i>
Tire carcass diameter	<i>L</i>
Tire carcass section height, loaded	<i>L</i>
Tire carcass section height, unloaded	<i>L</i>
Tire contact area	<i>L</i> ²
Tire contact pressure	<i>FL</i> ⁻²
Tire contact length	<i>L</i>
Tire contact width	<i>L</i>
Tire deflection	<i>L</i>
Tire deflection, maximum hard surface	<i>L</i>
Tire deflection, maximum in-soil deflection	<i>L</i>
Tire, diagonal ply (conventional)	<i>N/A</i>
Tire diameter	<i>L</i>
Tire inflation pressure	<i>FL</i> ⁻²
Tire, radial ply	<i>N/A</i>
Tire rolling circumference	<i>L</i>
Tire rolling radius	<i>L</i>
Tire section height	<i>L</i>
Tire section width, loaded	<i>L</i>
Tire section width, unloaded	<i>L</i>
Tire tread	<i>N/A</i>
Tire tread height	<i>L</i>
Tire radius	<i>L</i>
Tread width	<i>L</i>
Undertread face	<i>L</i> ²
<i>Track terms</i>	
Grouser	<i>N/A</i>
Grouser face	<i>L</i> ²
Track cleat	<i>N/A</i>
Track ground contact area	<i>L</i> ²
Track ground contact area, nominal	<i>L</i> ²
Track ground contact length	<i>L</i>
Track ground contact length, nominal	<i>L</i>
Track ground contact pressure	<i>FL</i> ⁻²
Track ground contact pressure, nominal	<i>FL</i> ⁻²
Track ground contact width	<i>L</i>
Track grouser height	<i>L</i>
Track grouser spacing or pitch	<i>L</i>
Track grouser width	<i>L</i>
Track link pitch	<i>L</i>
Track pad or plate	<i>N/A</i>
Track pitch	<i>L</i>
Track shoe	<i>N/A</i>
Track shoe face	<i>L</i> ²
Track type	<i>N/A</i>

REFERENCES

- [1] U.S. ARMY ENGINEER WATERWAYS EXPERIMENT STATION, CE, *Environmental Factors Affecting Ground Mobility in Thailand, Preliminary Survey*. Technical Report No. 5-625, Vicksburg, Mississippi (1963).
- [2] TRIPARTITE WORKING GROUP ON GROUND MOBILITY, Proposed dictionary of ground mobility terms. *Tripartite Working Group on Ground Mobility; Report on Third Conference, 31 August-15 September 1961*, Office of the Chief of Research and Development, U.S. Army, Washington, D.C., pp. B1-B11.
- [3] R. D. WISMER, *Identification of Design Parameters for the Off-Road Mobility Problem*. Presented at ISTVS Meeting at Houghton, Michigan, 9-10 February (1965).
- [4] U.S. ARMY TRANSPORTATION COMBAT DEVELOPMENTS AGENCY, *Logistical Vehicle Off-Road Mobility*. Final Report, Project TCCD 62-5, Fort Eustis, Virginia, February (1963).
- [5] U.S. ARMY ORDNANCE SCHOOL, *Ordnance Technical Terminology*. Special Text ST 9-152, Aberdeen Proving Ground, Maryland (1962).
- [6] TERMINOLOGY SUBCOMMITTEE, *Proposed Terminology*. Tractive and Transport Efficiency Committee, Am. Soc. Agric. Engrs., 30 September (1964).
- [7] U.S. ARMY ENGINEER WATERWAYS EXPERIMENT STATION, CE, *Performance of Soils Under Tire Loads, Test Facilities and Techniques*. Technical Report No. 3-666, Report No. 1, Vicksburg, Mississippi, January (1965).